

Polymer PTC Resettable Fuse: KRG-C Series

Radial Leded Type for Automotive Applications



■ Features

1. RoHS & Halogen-Free (HF) compliant
2. Radial leaded devices
3. Resettable device for automotive applications
4. Hold current rating from 0.1A to 15A
5. Maximum voltage: 6~60Vdc
6. Operating & storage temperature range: -40 ~ +85°C
7. Agency recognition: UL/cUL/TUV
8. AEC-Q200 compliant

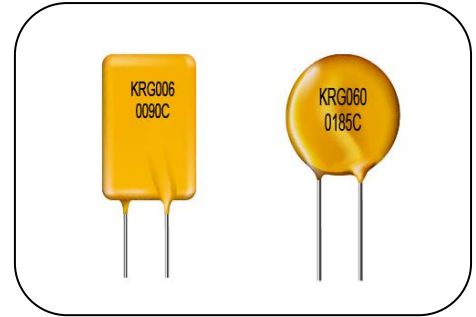

■ Recommended Applications

1. Protection of automotive electronics module
2. Protection of DC motor
3. Harness protection

■ Part Number Code

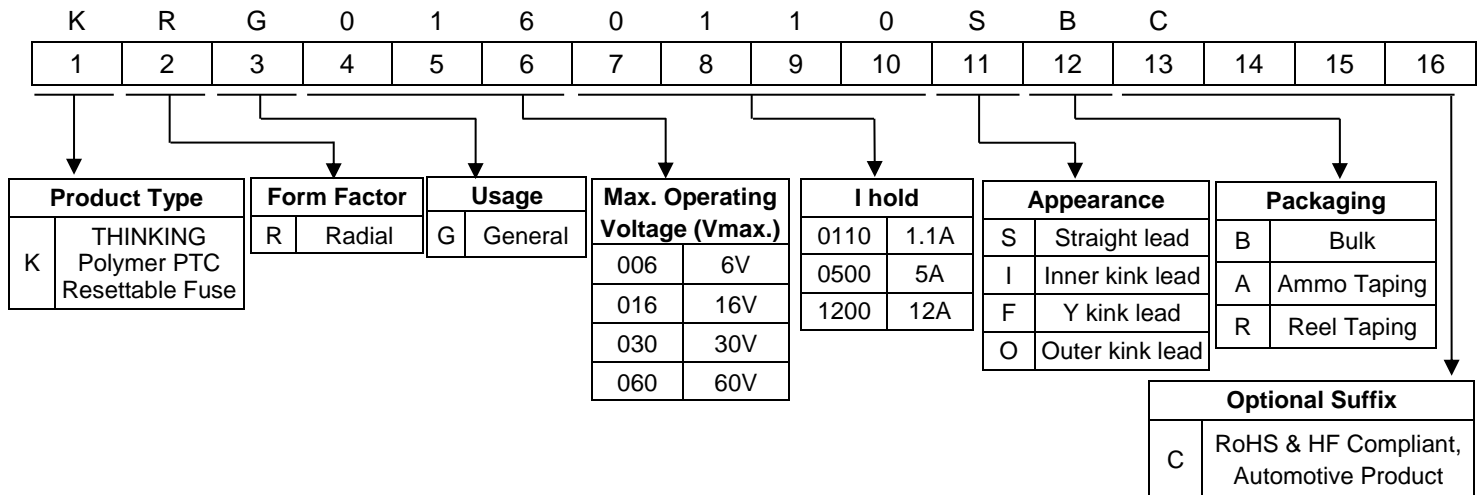

Polymer PTC Resettable Fuse: KRG-C Series

Radial Leded Type for Automotive Applications



Structure and Dimensions

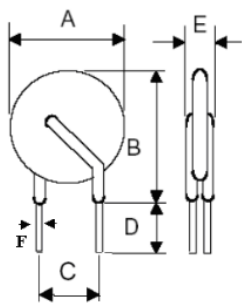

Style 1

S Type (Straight Lead)

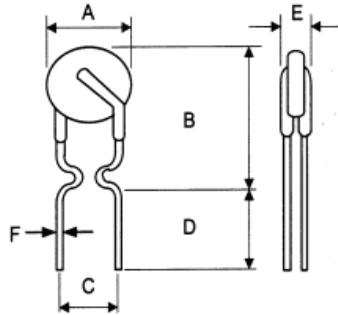

Style 2

I Type (Inner Kink Lead)

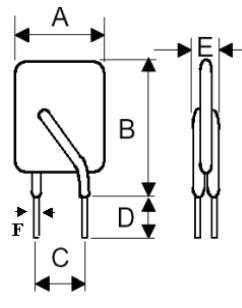

Style 3

S Type (Straight Lead)

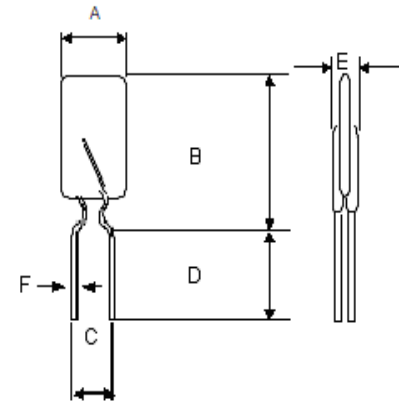

Style 4

I Type (Inner Kink Lead)

Marking: Device is marked with product type, Vmax, and I hold. C stands for automotive

● KRG006

(Unit: mm)

Part No.	A		B				C		D		E		F		Style
	Min.	Max.	Min.		Max.		Min.	Max.	Min.	Max.	Min.	Max.	Min.	Max.	
			Straight Lead	Inner Kink	Straight Lead	Inner Kink									
KRG0060075	4.76	7.00	4.66	8.36	9.36	11.40	4.2	5.8	7.6	11.6	1.6	3.1	0.48	0.52	2
KRG0060120	5.16	7.00	5.06	8.76	9.76	11.70	4.2	5.8	7.6	11.6	1.6	3.1	0.48	0.52	2
KRG0060155	6.00	6.90	6.25	9.95	10.95	11.70	4.2	5.8	7.6	11.6	1.6	3.1	0.48	0.52	2

● KRG016

(Unit: mm)

Part No.	A		B				C		D		E		F		Style
	Min.	Max.	Min.		Max.		Min.	Max.	Min.	Max.	Min.	Max.	Min.	Max.	
			Straight Lead	Inner Kink	Straight Lead	Inner Kink									
KRG0160090	5.5	7.1	6.9	10.6	11.6	12.2	4.2	5.8	7.6	11.6	1.6	3.1	0.48	0.52	3, 4
KRG0160110	5.5	7.1	8.9	12.6	13.6	14.2	4.2	5.8	7.6	11.6	1.6	3.1	0.48	0.52	3, 4
KRG0160135	8.0	8.9	7.9	11.6	12.6	13.5	4.2	5.8	7.6	11.6	1.6	3.1	0.48	0.52	3, 4
KRG0160160	8.0	8.9	9.6	13.3	14.3	15.2	4.2	5.8	7.6	11.6	1.6	3.1	0.48	0.52	3, 4
KRG0160185	9.0	10.2	10.5	14.2	15.2	15.7	4.2	5.8	7.6	11.6	1.6	3.1	0.48	0.52	3, 4
KRG0160250	10.6	11.4	12.7	16.4	17.4	18.4	4.2	5.8	7.6	11.6	1.6	3.1	0.48	0.52	3, 4
KRG0160300	6.3	7.1	6.2	9.9	10.9	11.9	4.2	5.8	7.6	11.6	2.0	3.5	0.78	0.82	3, 4
KRG0160400	8.1	8.9	8.0	11.7	12.7	13.7	4.2	5.8	7.6	11.6	2.0	3.5	0.78	0.82	3, 4
KRG0160500	9.6	10.4	9.5	13.2	14.2	15.2	4.2	5.8	7.6	11.6	2.0	3.5	0.78	0.82	3, 4
KRG0160600	9.9	10.7	12.3	16.0	17.0	18.0	4.2	5.8	7.6	11.6	2.0	3.5	0.78	0.82	3, 4
KRG0160700	10.4	11.2	14.8	18.5	19.5	20.5	4.2	5.8	7.6	11.6	2.0	3.5	0.78	0.82	3, 4
KRG0160800	11.9	12.7	16.1	20.3	20.8	22.3	4.2	5.8	7.6	11.6	2.0	3.5	0.78	0.82	3, 4
KRG0160900	13.2	14.0	16.8	21.0	21.5	23.0	4.2	5.8	7.6	11.6	2.0	3.5	0.78	0.82	3, 4
KRG0161000	15.7	16.5	21.3	25.5	25.2	27.5	4.2	5.8	7.6	11.6	2.0	3.5	0.78	0.82	3, 4
KRG0161100	16.7	17.5	21.3	25.5	26.0	27.5	4.2	5.8	7.6	11.6	2.0	3.5	0.78	0.82	3, 4
KRG0161200	16.7	17.5	22.7	26.9	27.4	28.9	9.2	10.8	7.6	11.6	2.0	3.5	0.98	1.02	3, 4
KRG0161300	20.9	21.6	23.9	28.1	28.6	30.1	9.2	10.8	7.6	11.6	2.0	3.5	0.98	1.02	3, 4
KRG0161400	22.8	23.5	22.7	26.9	27.4	28.9	9.2	10.8	7.6	11.6	2.0	3.5	0.98	1.02	3, 4
KRG0161500	23.9	25.1	23.8	28.0	28.5	30.0	9.2	10.8	7.6	11.6	2.0	3.5	0.98	1.02	3, 4

Polymer PTC Resettable Fuse: KRG-C Series

Radial Leded Type for Automotive Applications



● KRG030

(Unit: mm)

Part No.	A		B				C		D		E		F		Style
	Min.	Max.	Min.		Max.		Min.	Max.	Min.	Max.	Min.	Max.	Min.	Max.	
			Straight Lead	Inner Kink	Straight Lead	Inner Kink									
KRG0300090	5.5	7.1	6.9	10.6	11.6	12.2	4.2	5.8	7.6	11.6	1.7	3.0	0.48	0.52	3, 4
KRG0300110	5.5	7.1	8.9	12.6	13.6	14.2	4.2	5.8	7.6	11.6	1.7	3.0	0.48	0.52	3, 4
KRG0300135	8.0	8.9	7.9	11.6	12.6	13.5	4.2	5.8	7.6	11.6	1.7	3.0	0.48	0.52	3, 4
KRG0300160	8.0	8.9	9.6	13.3	14.3	15.2	4.2	5.8	7.6	11.6	1.7	3.0	0.48	0.52	3, 4
KRG0300185	9.0	10.2	10.5	14.2	15.2	15.7	4.2	5.8	7.6	11.6	1.7	3.0	0.48	0.52	3, 4
KRG0300250	10.6	11.4	12.7	16.4	17.4	18.4	4.2	5.8	7.6	11.6	1.7	3.0	0.48	0.52	3, 4
KRG0300300	10.6	11.4	12.7	16.4	17.3	18.4	4.2	5.8	7.6	11.6	1.8	3.5	0.78	0.82	3, 4
KRG0300400	13.1	14.0	14.5	18.2	19.2	20.2	4.2	5.8	7.6	11.6	1.8	3.5	0.78	0.82	3, 4
KRG0300500	13.1	14.0	19.3	23.5	24.0	25.5	9.2	10.8	7.6	11.6	1.8	3.5	0.78	0.82	3, 4
KRG0300600	15.6	16.5	19.3	23.5	24.0	25.5	9.2	10.8	7.6	11.6	1.8	3.5	0.78	0.82	3, 4
KRG0300700	18.2	19.1	21.1	25.3	25.8	27.3	9.2	10.8	7.6	11.6	1.8	3.5	0.78	0.82	3, 4
KRG0300800	20.7	21.6	23.7	27.9	28.4	29.9	9.2	10.8	7.6	11.6	1.8	3.5	0.78	0.82	3, 4
KRG0300900	23.3	24.1	23.2	27.4	27.9	29.4	9.2	10.8	7.6	11.6	1.8	3.5	0.78	0.82	3, 4

● KRG060

(Unit: mm)

Part No.	A		B				C		D		E		F		Style
	Min.	Max.	Min.		Max.		Min.	Max.	Min.	Max.	Min.	Max.	Min.	Max.	
			Straight Lead	Inner Kink	Straight Lead	Inner Kink									
KRG0600010	3.80	6.00	3.70	9.40	8.4	11.40	4.2	5.8	7.6	11.6	1.7	3.0	0.48	0.52	1, 2
KRG0600017	4.90	6.80	4.80	10.50	9.5	12.50	4.2	5.8	7.6	11.6	1.7	3.0	0.48	0.52	1, 2
KRG0600020	4.20	6.20	4.10	9.80	8.8	11.80	4.2	5.8	7.6	11.6	1.7	3.0	0.48	0.52	1, 2
KRG0600025	4.76	6.60	4.66	10.36	9.36	12.36	4.2	5.8	7.6	11.6	1.7	3.0	0.48	0.52	1, 2
KRG0600030	5.16	6.76	5.06	10.76	9.76	12.76	4.2	5.8	7.6	11.6	1.7	3.0	0.48	0.52	1, 2
KRG0600040	6.35	7.60	6.25	10.95	10.95	13.15	4.2	5.8	7.6	11.6	1.7	3.0	0.48	0.52	1, 2
KRG0600050	6.75	7.60	6.65	11.35	11.35	13.55	4.2	5.8	7.6	11.6	1.7	3.0	0.48	0.52	1, 2
KRG0600065	8.34	9.70	8.24	12.44	12.94	14.50	4.2	5.8	7.6	11.6	1.7	3.0	0.48	0.52	1, 2
KRG0600075	9.13	10.40	9.03	13.23	13.73	15.20	4.2	5.8	7.6	11.6	1.7	3.0	0.48	0.52	1, 2
KRG0600090	9.90	11.70	9.80	14.00	14.5	15.70	4.2	5.8	7.6	11.6	1.7	3.0	0.48	0.52	1, 2
KRG0600110	11.51	13.00	11.41	16.11	16.11	18.00	4.2	5.8	7.6	11.6	2.0	3.5	0.78	0.82	1, 2
KRG0600135	13.10	14.50	13.00	17.70	17.7	19.60	4.2	5.8	7.6	11.6	2.0	3.5	0.78	0.82	1, 2
KRG0600160	14.69	16.30	14.59	19.29	19.29	21.19	4.2	5.8	7.6	11.6	2.0	3.5	0.78	0.82	1, 2
KRG0600185	16.28	17.80	16.18	20.38	20.88	22.38	4.2	5.8	7.6	11.6	2.0	3.5	0.78	0.82	1, 2
KRG0600250	19.45	21.30	19.35	23.55	24.05	25.55	9.2	10.8	7.6	11.6	2.0	3.5	0.78	0.82	1, 2
KRG0600300	22.62	24.90	22.52	26.72	27.22	28.72	9.2	10.8	7.6	11.6	2.0	3.5	0.78	0.82	1, 2
KRG0600375	25.80	28.40	25.70	29.90	30.4	31.90	9.2	10.8	7.6	11.6	2.0	3.5	0.78	0.82	1, 2

Polymer PTC Resettable Fuse: KRG-C Series

Radial Leaded Type for Automotive Applications



■ Electrical Characteristics

● KRG006

Part No.	Vmax.	I _{max.}	I _{hold}	I _{trip}	P _d (Typ.)	Maximum Time to Trip		Resistance			Safety Approvals	
	(V _{dc})	(A)	(A)	(A)	(W)	Current	Time	Initial R _i		Post Trip R ₁	UL/ cUL	TUV
						(A)	(Sec)	Min. (Ω)	Max. (Ω)	Max.(Ω)		
KRG0060075	6	40	0.75	1.50	0.30	8.00	0.40	0.1100	0.1750	0.2300	√	√
KRG0060120	6	40	1.20	2.40	0.60	8.00	0.50	0.0650	0.0975	0.1400	√	√
KRG0060155	6	40	1.55	3.10	0.70	7.80	2.20	0.0430	0.0705	0.1000	√	√

● KRG016

Part No.	Vmax.	I _{max.}	I _{hold}	I _{trip}	P _d (Typ.)	Maximum Time to Trip		Resistance			Safety Approvals	
	(V _{dc})	(A)	(A)	(A)	(W)	Current	Time	Initial R _i		Post Trip R ₁	UL/ cUL	TUV
						(A)	(Sec)	Min. (Ω)	Max. (Ω)	Max. (Ω)		
KRG0160090	16	40	0.90	1.80	0.60	8.00	1.20	0.070	0.120	0.180	√	√
KRG0160110	16	40	1.10	2.20	0.70	8.00	2.30	0.050	0.095	0.140	√	√
KRG0160135	16	40	1.35	2.70	0.80	8.00	4.50	0.040	0.074	0.120	√	√
KRG0160160	16	40	1.60	3.20	0.90	8.00	9.00	0.030	0.061	0.110	√	√
KRG0160185	16	40	1.85	3.70	1.00	8.00	10.00	0.030	0.051	0.090	√	√
KRG0160250	16	40	2.50	5.00	1.20	8.00	40.00	0.020	0.036	0.070	√	√
KRG0160300	16	100	3.00	5.10	2.30	15.00	1.00	0.038	0.065	0.098	√	√
KRG0160400	16	100	4.00	6.80	2.40	20.00	1.70	0.021	0.038	0.060	√	√
KRG0160500	16	100	5.00	8.50	2.60	25.00	2.00	0.010	0.023	0.034	√	√
KRG0160600	16	100	6.00	10.20	2.80	30.00	3.30	0.006	0.018	0.028	√	√
KRG0160700	16	100	7.00	11.90	3.00	35.00	3.50	0.006	0.013	0.020	√	√
KRG0160800	16	100	8.00	13.60	3.00	40.00	5.00	0.005	0.011	0.018	√	√
KRG0160900	16	100	9.00	15.30	3.30	45.00	5.50	0.005	0.009	0.014	√	√
KRG0161000	16	100	10.00	17.00	3.60	50.00	6.00	0.004	0.007	0.010	√	√
KRG0161100	16	100	11.00	18.70	3.70	55.00	7.00	0.003	0.006	0.009	√	√
KRG0161200	16	100	12.00	20.40	4.20	60.00	7.50	0.003	0.006	0.009	√	√
KRG0161300	16	100	13.00	22.10	4.60	65.00	8.50	0.002	0.006	0.008	√	√
KRG0161400	16	100	14.00	23.80	4.60	70.00	9.00	0.002	0.005	0.007	√	√
KRG0161500	16	100	15.00	25.50	4.60	75.00	10.00	0.002	0.005	0.007	√	√

Note: UL&cUL File No.: E138827

TUV File No.: J 50161442

Polymer PTC Resettable Fuse: KRG-C Series

Radial Leaded Type for Automotive Applications



■ Electrical Characteristics

● KRG030

Part No.	Vmax.	I _{max.}	I _{hold}	I _{trip}	Pd (Typ.)	Maximum Time to Trip		Resistance			Safety Approvals	
	(V _{dc})	(A)	(A)	(A)	(W)	Current	Time	Initial Ri		Post Trip R1	UL/ cUL	TUV
						(A)	(Sec)	Min. (Ω)	Max. (Ω)	Max.(Ω)		
KRG0300090	30	40	0.90	1.80	0.60	8.00	1.20	0.070	0.120	0.180	√	√
KRG0300110	30	40	1.10	2.20	0.70	8.00	2.30	0.050	0.095	0.140	√	√
KRG0300135	30	40	1.35	2.70	0.80	8.00	4.50	0.040	0.074	0.120	√	√
KRG0300160	30	40	1.60	3.20	0.90	8.00	9.00	0.030	0.061	0.110	√	√
KRG0300185	30	40	1.85	3.70	1.00	8.00	10.00	0.030	0.051	0.090	√	√
KRG0300250	30	40	2.50	5.00	1.20	8.00	40.00	0.020	0.036	0.070	√	√
KRG0300300	30	40	3.00	6.00	2.30	15.00	1.00	0.038	0.065	0.098	√	√
KRG0300400	30	40	4.00	8.00	2.40	20.00	1.70	0.021	0.038	0.060	√	√
KRG0300500	30	40	5.00	10.00	2.60	25.00	2.00	0.010	0.023	0.034	√	√
KRG0300600	30	40	6.00	12.00	2.80	30.00	3.30	0.006	0.018	0.028	√	√
KRG0300700	30	40	7.00	14.00	3.00	35.00	3.50	0.006	0.013	0.020	√	√
KRG0300800	30	40	8.00	16.00	3.00	40.00	5.00	0.005	0.011	0.018	√	√
KRG0300900	30	40	9.00	18.00	3.30	45.00	5.50	0.005	0.009	0.014	√	√

● KRG060

Part No.	Vmax.	I _{max.}	I _{hold}	I _{trip}	Pd (Typ.)	Maximum Time to Trip		Resistance			Safety Approvals	
	(V _{dc})	(A)	(A)	(A)	(W)	Current	Time	Initial Ri		Post Trip R1	UL/ cUL	TUV
						(A)	(Sec)	Min. (Ω)	Max. (Ω)	Max.(Ω)		
KRG0600010	60	40	0.10	0.20	0.38	0.50	4.00	2.500	4.500	7.500	√	√
KRG0600017	60	40	0.17	0.34	0.48	0.85	3.00	3.300	5.210	8.000	√	√
KRG0600020	60	40	0.20	0.40	0.41	1.00	2.20	1.830	2.750	4.400	√	√
KRG0600025	60	40	0.25	0.50	0.45	1.25	2.50	1.250	1.950	3.000	√	√
KRG0600030	60	40	0.30	0.60	0.49	1.50	3.00	0.880	1.330	2.100	√	√
KRG0600040	60	40	0.40	0.80	0.56	2.00	3.80	0.550	0.860	1.290	√	√
KRG0600050	60	40	0.50	1.00	0.77	2.50	4.00	0.500	0.770	1.170	√	√
KRG0600065	60	40	0.65	1.30	0.88	3.25	5.30	0.310	0.480	0.720	√	√
KRG0600075	60	40	0.75	1.50	0.92	3.75	6.30	0.250	0.400	0.600	√	√
KRG0600090	60	40	0.90	1.80	0.99	4.50	7.20	0.200	0.310	0.470	√	√
KRG0600110	60	40	1.10	2.20	1.50	5.50	8.20	0.150	0.250	0.380	√	√
KRG0600135	60	40	1.35	2.70	1.70	6.75	9.60	0.120	0.190	0.300	√	√
KRG0600160	60	40	1.60	3.20	1.90	8.00	11.40	0.090	0.140	0.220	√	√
KRG0600185	60	40	1.85	3.70	2.10	9.25	12.60	0.080	0.120	0.190	√	√
KRG0600250	60	40	2.50	5.00	2.50	12.50	15.60	0.050	0.080	0.130	√	√
KRG0600300	60	40	3.00	6.00	2.80	15.00	19.80	0.040	0.060	0.100	√	√
KRG0600375	60	40	3.75	7.50	3.20	18.75	24.00	0.030	0.050	0.080	√	√

Note: UL&cUL File No.: E138827

Polymer PTC Resettable Fuse: KRG-C Series

Radial Leded Type for Automotive Applications



TUV File No.: J 50161442

Polymer PTC Resettable Fuse: KRG-C Series

Radial Leded Type for Automotive Applications



Typical Time to Trip Curves at 23°C

KRG006 Series

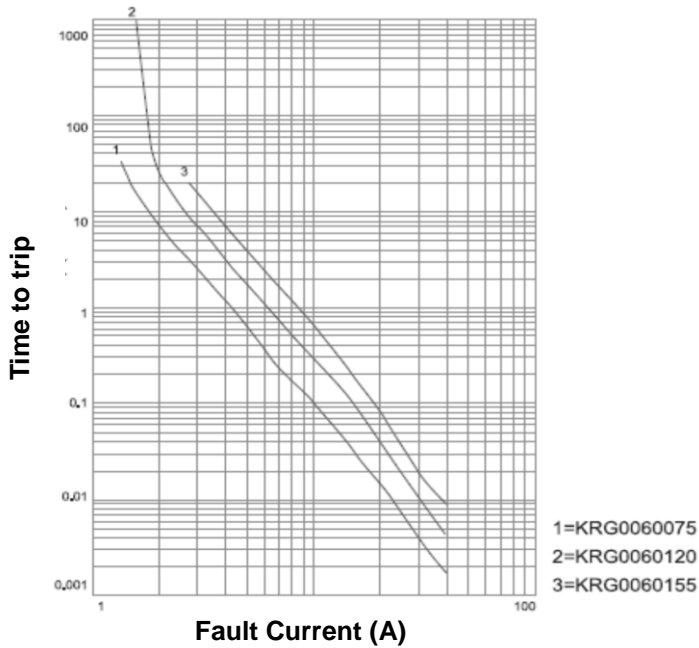

KRG016 Series

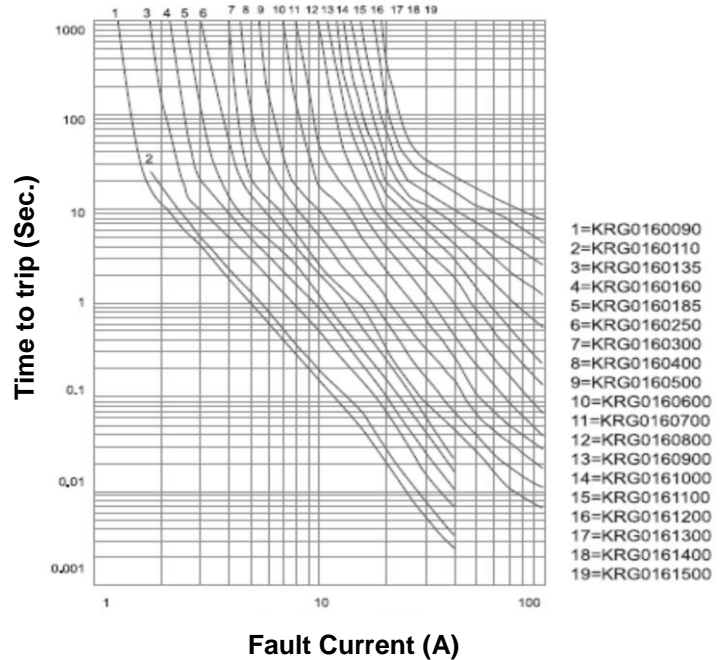

KRG030 Series

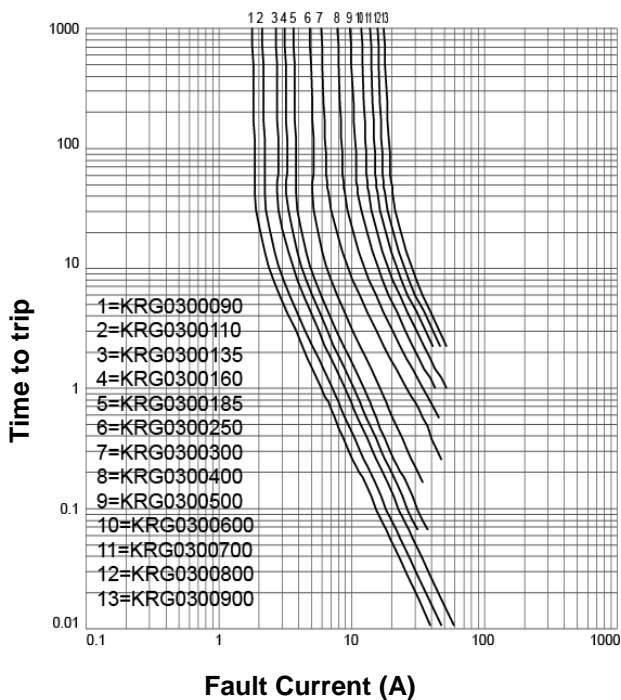

KRG060 Series

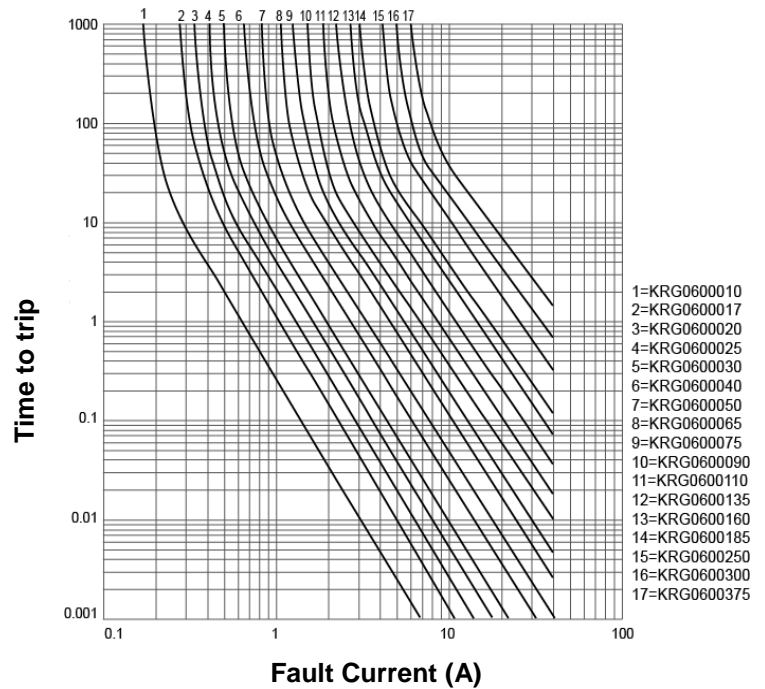

Polymer PTC Resettable Fuse: KRG-C Series

Radial Leded Type for Automotive Applications



■ Ihold & Itrip Thermal Derating Curve

Derating Curve for KRG006/KRG016 Series

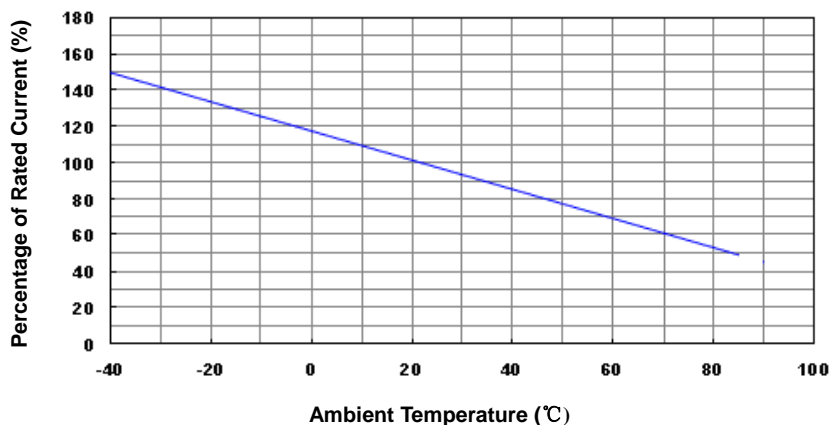

Derating Curve for KRG030 Series

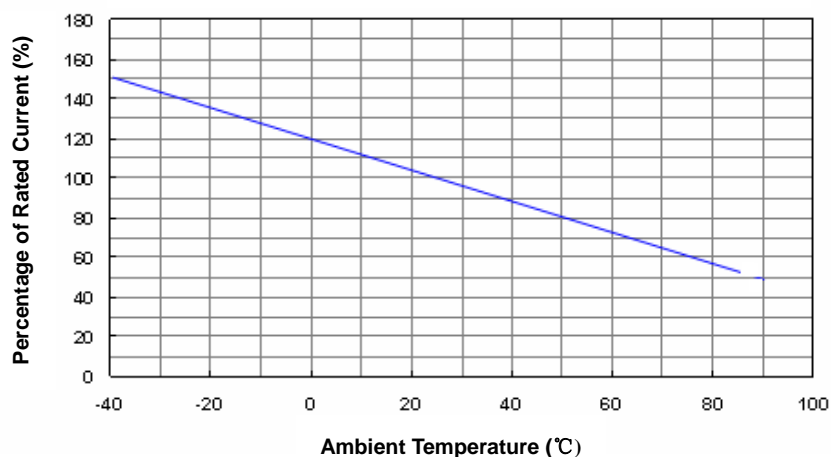

Derating Curve for KRG060 Series

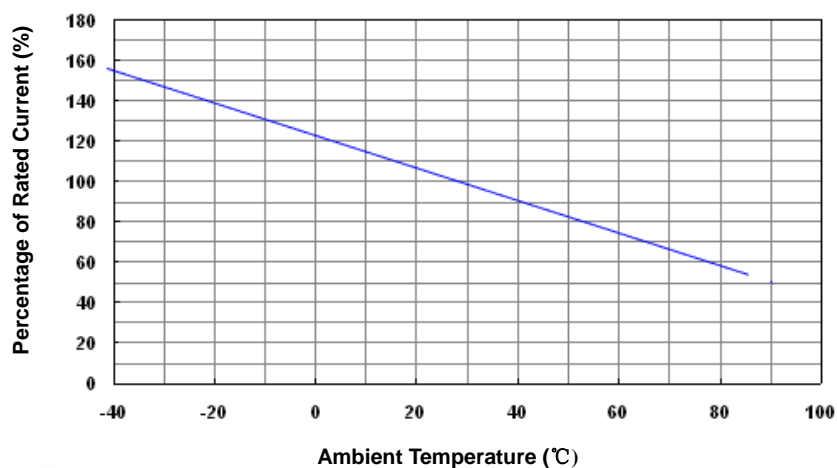

Polymer PTC Resettable Fuse: KRG-C Series

Radial Leded Type for Automotive Applications



Hold Thermal Derating Chart

● KRG006 Series

(Unit: A)

Part No.	Ambient Temperature								
	-40°C	-20°C	0°C	23°C	40°C	50°C	60°C	70°C	85°C
KRG0060075	1.05	0.95	0.85	0.75	0.64	0.58	0.51	0.44	0.35
KRG0060120	1.69	1.52	1.36	1.20	1.02	0.92	0.82	0.71	0.56
KRG0060155	2.17	1.96	1.75	1.55	1.32	1.19	1.05	0.91	0.73

● KRG016 Series

(Unit: A)

Part No.	Ambient Temperature								
	-40°C	-20°C	0°C	23°C	40°C	50°C	60°C	70°C	85°C
KRG0160090	1.33	1.20	1.05	0.90	0.77	0.69	0.61	0.53	0.42
KRG0160110	1.63	1.46	1.29	1.10	0.94	0.85	0.75	0.65	0.52
KRG0160135	2.00	1.80	1.58	1.35	1.15	1.04	0.92	0.80	0.63
KRG0160160	2.37	2.13	1.87	1.60	1.36	1.23	1.09	0.94	0.75
KRG0160185	2.74	2.46	2.16	1.85	1.57	1.42	1.26	1.09	0.87
KRG0160250	3.63	3.25	2.88	2.50	2.08	1.93	1.70	1.48	1.18
KRG0160300	4.40	3.96	3.60	3.00	2.55	2.31	2.10	1.77	1.35
KRG0160400	5.90	5.28	4.80	4.00	3.40	3.08	2.80	2.36	1.80
KRG0160500	7.30	6.60	6.00	5.00	4.25	3.85	3.60	2.95	2.25
KRG0160600	8.80	7.92	7.20	6.00	5.10	4.62	4.20	3.54	2.70
KRG0160700	10.30	9.24	8.40	7.00	5.95	5.39	5.00	4.13	3.15
KRG0160800	11.70	10.56	9.60	8.00	6.80	6.16	5.60	4.72	3.60
KRG0160900	13.20	11.88	10.70	9.00	7.65	6.93	6.40	5.31	4.05
KRG0161000	14.70	13.20	12.00	10.00	8.50	7.70	7.00	5.90	4.50
KRG0161100	16.10	14.52	13.10	11.00	9.35	8.47	7.80	6.49	4.95
KRG0161200	17.60	15.84	14.40	12.00	10.20	9.24	8.40	7.08	5.40
KRG0161300	17.70	16.30	14.80	13.00	11.05	10.01	9.60	7.67	5.85
KRG0161400	20.50	18.48	16.80	14.00	11.90	10.78	9.80	8.26	6.30
KRG0161500	20.40	18.80	17.10	15.00	12.75	11.55	11.10	8.85	6.75

Polymer PTC Resettable Fuse: KRG-C Series

Radial Leded Type for Automotive Applications



Hold Thermal Derating Chart

● KRG030 Series

(Unit: A)

Part No.	Ambient Temperature								
	-40℃	-20℃	0℃	23℃	40℃	50℃	60℃	70℃	85℃
KRG0300090	1.38	1.22	1.08	0.90	0.78	0.70	0.62	0.55	0.45
KRG0300110	1.68	1.50	1.32	1.10	0.96	0.86	0.76	0.67	0.55
KRG0300135	2.07	1.84	1.62	1.35	1.17	1.05	0.92	0.82	0.68
KRG0300160	2.45	2.18	1.92	1.60	1.39	1.25	1.09	0.98	0.80
KRG0300185	2.83	2.52	2.22	1.85	1.61	1.44	1.25	1.13	0.93
KRG0300250	3.83	3.40	3.00	2.50	2.18	1.95	1.71	1.53	1.25
KRG0300300	4.59	4.08	3.60	3.00	2.61	2.34	2.05	1.83	1.50
KRG0300400	6.12	5.44	4.80	4.00	3.48	3.12	2.72	2.44	2.00
KRG0300500	7.65	6.80	6.00	5.00	4.35	3.90	3.41	3.05	2.50
KRG0300600	9.18	8.16	7.20	6.00	5.22	4.68	4.09	3.66	3.00
KRG0300700	10.71	9.52	8.40	7.00	6.09	5.46	4.77	4.27	3.50
KRG0300800	12.24	10.88	9.60	8.00	6.96	6.24	5.45	4.88	4.00
KRG0300900	13.77	12.24	10.80	9.00	7.83	7.02	6.12	5.49	4.50

● KRG060 Series

(Unit: A)

Part No.	Ambient Temperature								
	-40℃	-20℃	0℃	23℃	40℃	50℃	60℃	70℃	85℃
KRG0600010	0.15	0.14	0.12	0.10	0.09	0.08	0.07	0.06	0.05
KRG0600017	0.26	0.23	0.20	0.17	0.15	0.13	0.11	0.09	0.08
KRG0600020	0.31	0.27	0.24	0.20	0.17	0.16	0.13	0.11	0.09
KRG0600025	0.38	0.34	0.30	0.25	0.22	0.20	0.16	0.14	0.13
KRG0600030	0.46	0.41	0.36	0.30	0.26	0.23	0.19	0.16	0.15
KRG0600040	0.61	0.54	0.48	0.40	0.35	0.31	0.25	0.22	0.20
KRG0600050	0.77	0.68	0.60	0.50	0.44	0.39	0.31	0.27	0.25
KRG0600065	0.99	0.88	0.78	0.65	0.57	0.51	0.41	0.36	0.33
KRG0600075	1.15	1.02	0.90	0.75	0.65	0.59	0.51	0.46	0.38
KRG0600090	1.38	1.22	1.08	0.90	0.78	0.70	0.62	0.55	0.45
KRG0600110	1.60	1.43	1.27	1.10	0.92	0.85	0.75	0.67	0.57
KRG0600135	1.96	1.76	1.55	1.35	1.12	1.04	0.92	0.83	0.70
KRG0600160	2.23	2.08	1.84	1.60	1.33	1.23	1.08	0.98	0.80
KRG0600185	2.68	2.41	2.13	1.85	1.54	1.43	1.26	1.13	0.90
KRG0600250	3.63	3.25	2.88	2.50	2.08	1.93	1.70	1.50	1.30
KRG0600300	4.35	3.90	3.45	3.00	2.50	2.30	1.90	1.80	1.50
KRG0600375	5.44	4.88	4.31	3.75	3.11	2.90	2.54	2.29	1.90

Polymer PTC Resettable Fuse: KRG-C Series

Radial Leaded Type for Automotive Applications



■ Reliability

Item	Standard	Test Condition/methods	Specifications
Resistance to Soldering Heat	IEC 60068-2-58	$260 \pm 5^{\circ}\text{C}$, 10 ± 1 sec	$R_f < R_{1\text{max}}$ No visible damage
Passive Aging	IEC 60738-1	$85 \pm 5^{\circ}\text{C}$, 1000 ± 24 hrs	$\pm 5\%$ typical resistance change
Humidity Aging	IEC 60068-2-78	$85 \pm 5^{\circ}\text{C}$, 80~85%RH, 1000 ± 5 hrs	$\pm 5\%$ typical resistance change
Rapid Change of Temperature	IEC 60738-1	$85 \pm 5 / -40 \pm 5^{\circ}\text{C}$, 10 cycles, Duration: 30min	$\pm 5\%$ typical resistance change
Overload Endurance	UL 1434	V_{max} , 120% I_{max} , 50 cycles V_{max} , 300% I_{trip} , 6000 cycles	No visible damage
Trip Endurance	UL 1434	V_{max} , $I_{\text{trip}} \leq I \leq I_{\text{max}}$, 1000 ± 24 hrs	No visible damage
ESD	AEC-Q200-002	Discharge capacitance: 150 pF Charging voltage: 6 KV Contact discharge 1 pulse in each polarity	$R_f \leq R_{1\text{max}}$
Short Circuit Fault Current Durability	AEC-Q200-004	V_r I_{sc} ON 5~10S/OFF 2min, 100cycles	No visible damage
Fault Current Durability	AEC-Q200-004	V_r I_{hold} ON 5~7min/OFF 10min, 6cycles	No visible damage
End-of-Life Mode Verification	AEC-Q200-004	V_r I_{trip} ON 5~10S/OFF 1min, 6000cycles	Open circuit after being burned
Jump Start Endurance	AEC-Q200-004	26V applied to $R_L \leq V_{\text{max}}/I_{\text{hold}}$, 1min on /2min off, 3Cycles	$R_f \leq R_{1\text{max}}$
Load Dump Endurance	AEC-Q200-004	A pulse shall be applied for 90 seconds for a total of 10 pulses, $R_L \leq V_{\text{max}}/I_{\text{hold}}$	Change rate of $R \leq 20\%$, No visible damage

Polymer PTC Resettable Fuse: KRG-C Series

Radial Leaded Type for Automotive Applications



■ Packaging

Devices are taped according to IEC 60286-2 standards. See table below and Fig.1~3 for details.

Dimension description	IEC Mark	Dimension (mm)	Tolerance (mm)
Sprocket hole pitch	P ₀	12.70	±0.3
Ordinate to adjacent component lead KRG0060075, KRG0060120, KRG0060155, KRG0160090~KRG0160250, KRG0160300~KRG0161100, KRG0300090~KRG0300400, KRG0600010~KRG0600185	P ₁	3.85	±0.7
Ordinate to adjacent component lead KRG0161200~KRG0161500, KRG0300500~KRG0300900, KRG0600250~KRG0600375		7.70	±0.7
Device pitch KRG0060075, KRG0060120, KRG0060155, KRG0160090~KRG0160600, KRG0300090~KRG0300300, KRG0600010~KRG0600090	P	12.70	±1.0
Device pitch KRG0160700~KRG0161400, KRG0300400~KRG0300900, KRG0600110~KRG0600300		25.40	±1.0
Device pitch KRG0161500, KRG0600375		38.10	±1.0
Lead spacing KRG0060075, KRG0060120, KRG0060155, KRG0160090~KRG0161100, KRG0300090~KRG0300400, KRG0600010~KRG0600185	C	5.00	±0.8
Lead spacing KRG0161200~KRG0161500, KRG0300500~KRG0300900, KRG0600250~KRG0600375		10.00	
Lead diameter KRG0060075, KRG0060120, KRG0060155, KRG0160090~KRG0160250, KRG0300090~KRG0300250, KRG0600010~KRG0600090	d	0.50	±0.02
Lead diameter KRG0160300~KRG0161500, KRG0300300~KRG0300900, KRG0600110~KRG0600300		0.80	
Carrier tape width	W	18.00	+1/-0.5
Top distance between tape edges	W ₂	3.00	Max
Hold-down tape width	W ₀	12.00	±1.5
Sprocket hole position	W ₁	9.00	+0.75/-0.5
Abscissa to top KRG0060075, KRG0060120, KRG0060155, KRG0160090~KRG0160600, KRG0300090~KRG0300300, KRG0600010~KRG0600090	H ₁	32.20	Max.
Abscissa to top KRG0160700~KRG0161500, KRG0300400~KRG0300900, KRG0600110~KRG0600375		47.50	
Abscissa to plane (straight lead)	H	18.00	+2/-0
Abscissa to plane (kinked lead)	H ₀	16.00	±0.5
Sprocket hole diameter	D ₀	4.00	±0.2
Lead protrusion	L ₁	0.50	Max.
Tape thickness	t	0.60	±0.2
Body lateral deviation	Δh	2.00	Max.
Body tape plane deviation	Δp	1.00	Max.
Reel width	W ₃	See reel specification	±1
Reel diameter		340.00	±10
Arbor hole diameter	n ₀	31.00	±1
Core diameter	n	80.00	Min.

Polymer PTC Resettable Fuse: KRG-C Series

Radial Leded Type for Automotive Applications



- Taping Specification

Fig.1 For KRG0060075, KRG0060120, KRG0060155

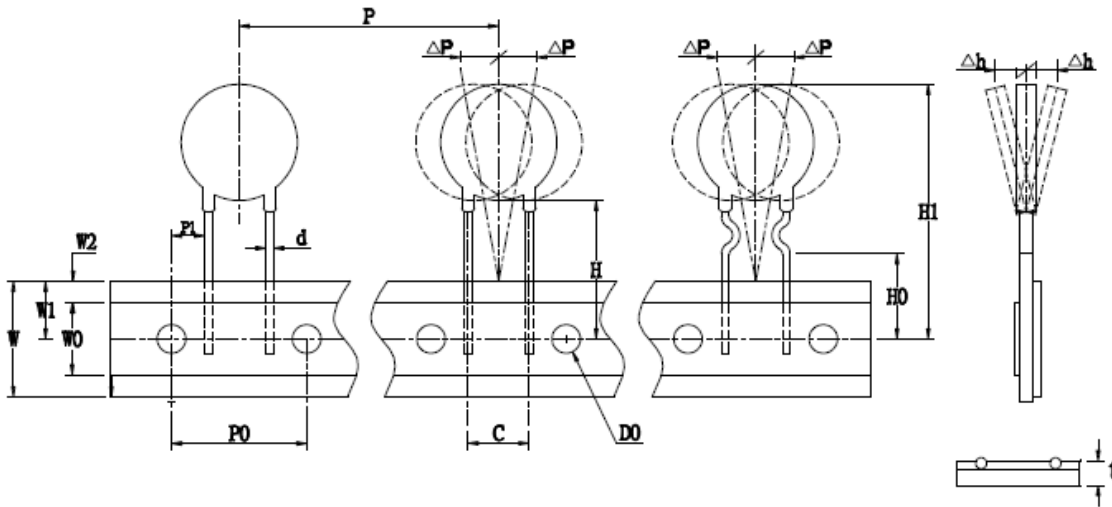

Fig.2 For KRG0160090-KRG0161100

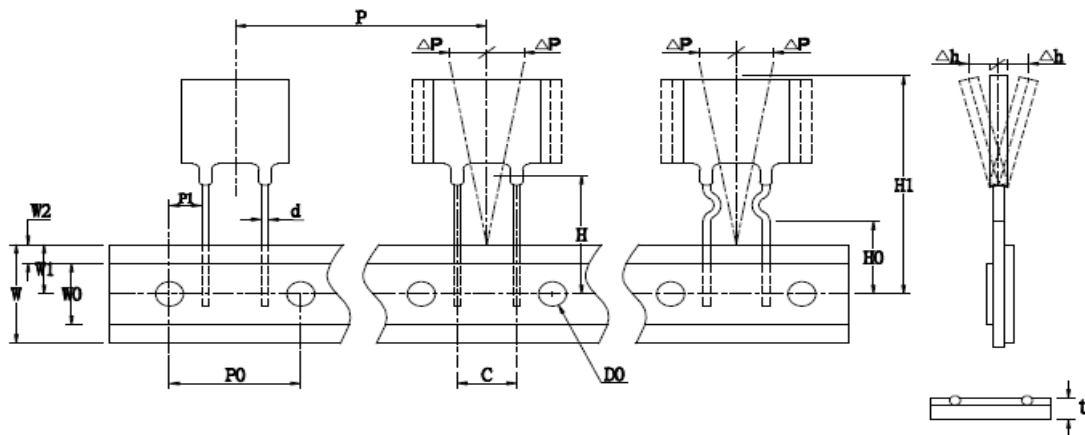
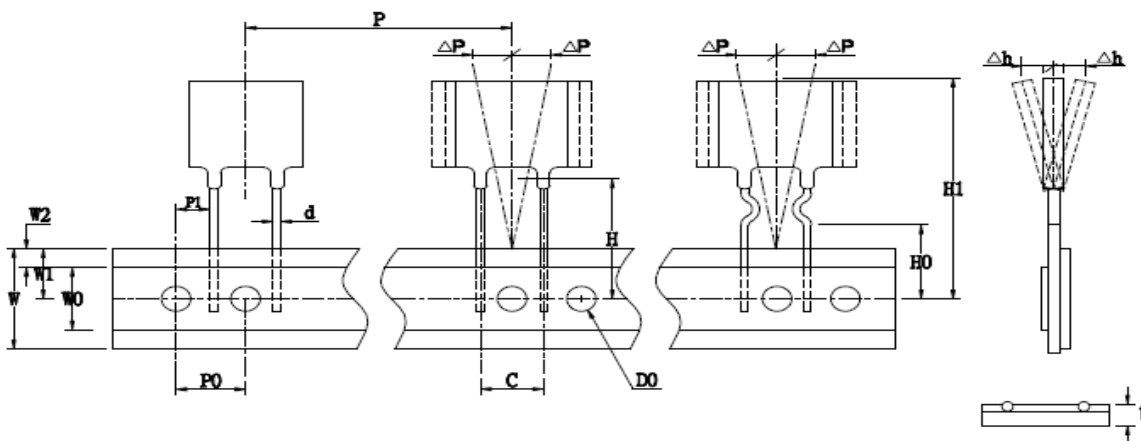

Fig.3 For KRG0161200-KRG0161500



Polymer PTC Resettable Fuse: KRG-C Series

Radial Leded Type for Automotive Applications



Fig.4 For KRG0300090-KRG0300400

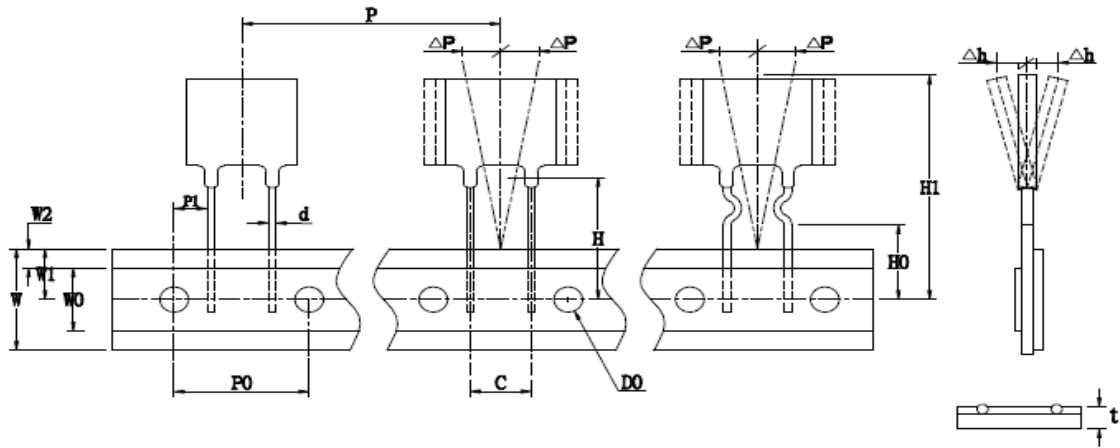

Fig.5 For KRG0300500-KRG0300900

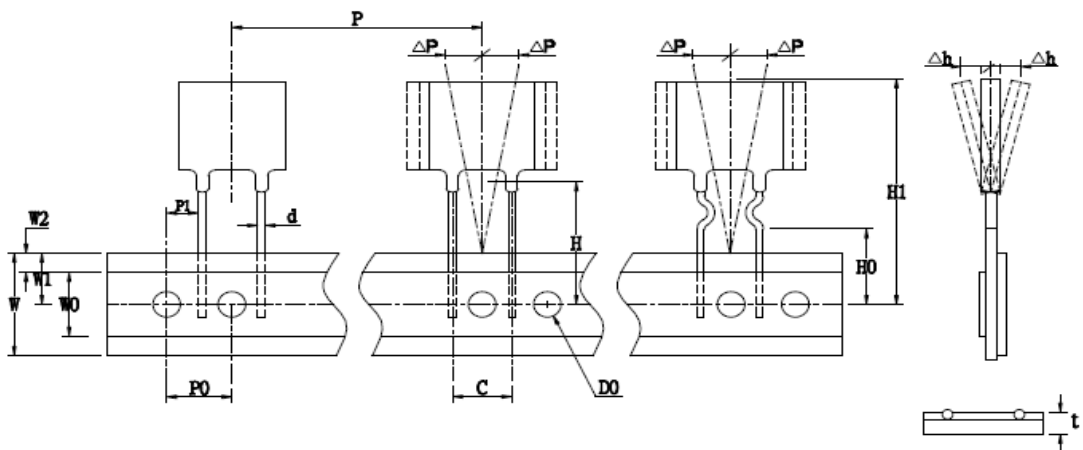
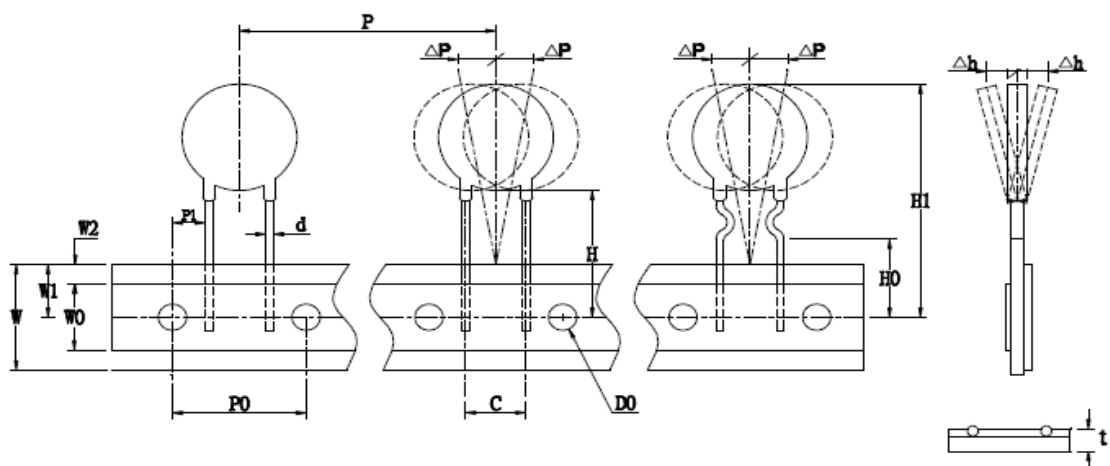

Fig.6 For KRG0600010-KRG0600185



Polymer PTC Resettable Fuse: KRG-C Series

Radial Leded Type for Automotive Applications



Fig.7 For KRG0600250-KRG0600375

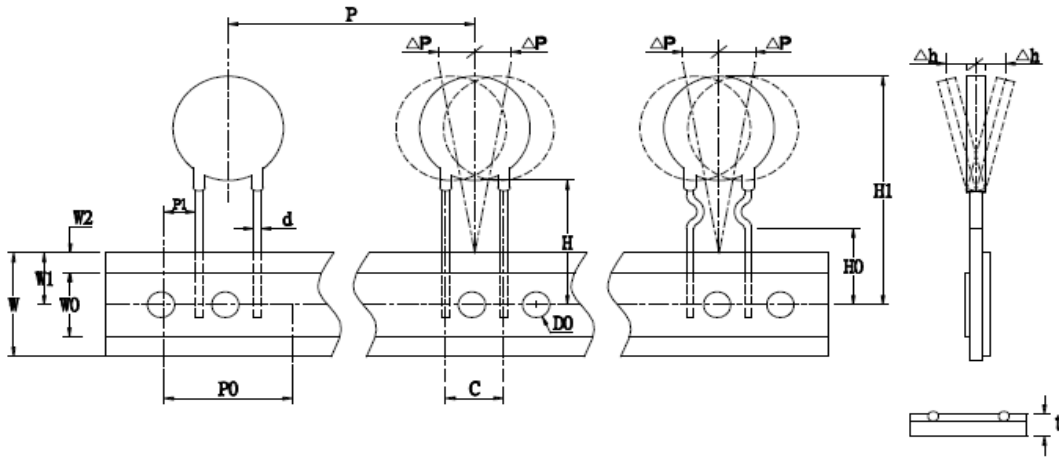

● Reel Specification

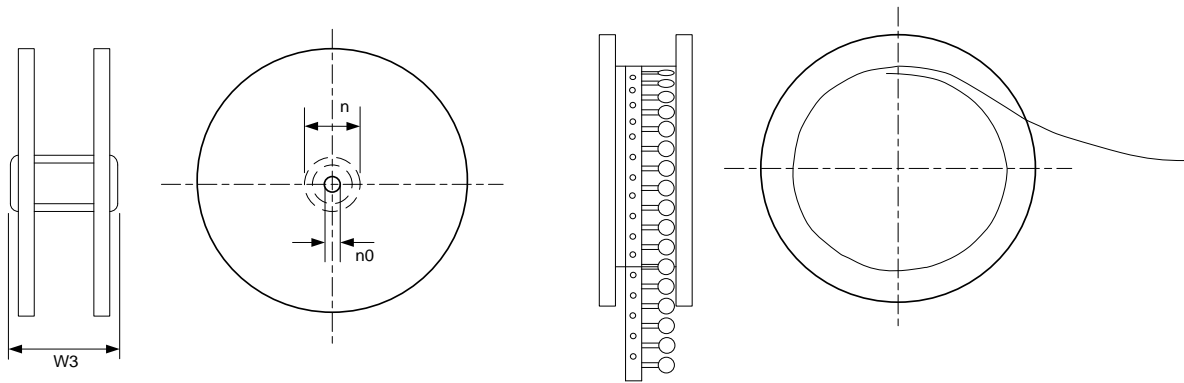

Series	W3 (mm)
KRG0060075-0155	46±1
KRG0160090-0800	
KRG0300090-0400	
KRG0600010-0185	52±1
KRG0160900-1100	
KRG0300500-0700	
KRG0600250	55±1
KRG0161200-1500	
KRG0300800-0900	
KRG0600300-0375	

Polymer PTC Resettable Fuse: KRG-C Series

Radial Leaded Type for Automotive Applications



■ Quantity

● Bulk Packing

Series	Quantity (pcs/bag)
KRG006 (0075~0155)	1,000
KRG016 (0090~0160)	
KRG030 (0090~0135)	
KRG060 (0010~0025)	
KRG016 (0185~0900)	500
KRG030 (0160~0600)	
KRG060 (0030~0185)	
KRG016(1000~1500)	250
KRG030(0800~0900)	
KRG060 (0250~0375)	
KRG0300700	200

● Reel Packing

Series	Quantity (pcs/reel)
KRG006 (0075~0155)	3,000
KRG016 (0090~0185)	
KRG030 (0090~0135)	
KRG060 (0010~0040)	
KRG016 (0250~0400)	2,500
KRG0600017	
KRG030 (0160~0300)	2,000
KRG060 (0050~0090)	
KRG016 (0500~0700)	1,500
KRG060 (0110~0185)	1,200
KRG016 (0800~1500)	1,000
KRG030 (0400~0900)	
KRG060 (0250~0375)	

Polymer PTC Resettable Fuse: KRG-C Series

Radial Leaded Type for Automotive Applications



● Ammo Packing

Series	Quantity (pcs/box)
KRG006 (0075~0155)	1,000
KRG016 (0090~0600)	
KRG030 (0090~0300)	
KRG060 (0010~0090)	
KRG016 (0700~1500)	500
KRG030 (0400~0900)	
KRG060 (0110~0375)	

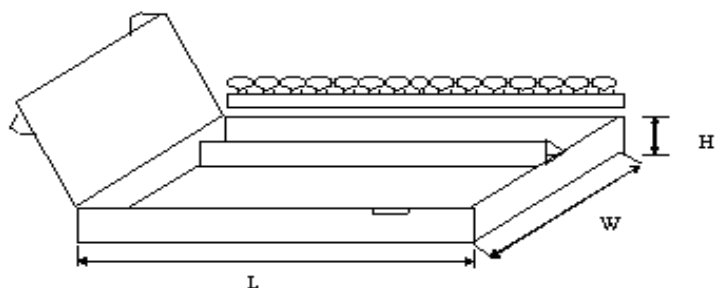

(Unit: mm)

Series	W	L	H
KRG006 (0075~0155)	345	275	55
KRG016 (0090~1500)			
KRG030 (0090~0900)			
KRG060 (0010~0375)			

■ Warehouse Storage Conditions of Products

- Storage Conditions:
 1. Storage Temperature: -10°C~+40°C
 2. Relative Humidity: $\leq 75\%RH$
 3. Keep away from corrosive atmosphere and sunlight.
- Period of Storage: 1 year